

Serial Number:

Puma 165-215 > Puma 185 - Tractor Dec 2010 Sep 2015 > 05 - Service & Maintenance > 05.100.04[01] - MAINTENANCE PARTS - FILTERS

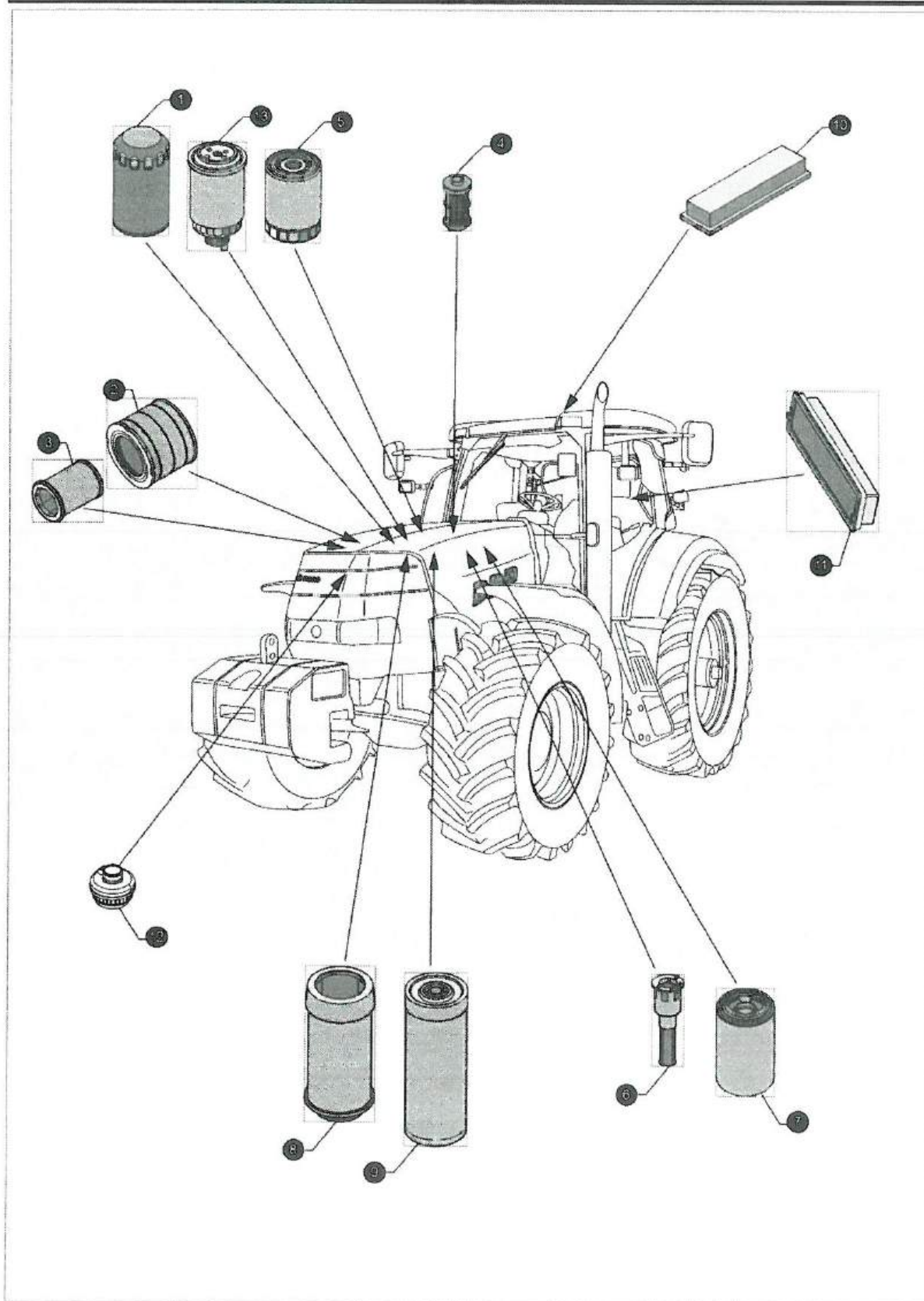













Serial Number:



Puma 165-215 > Puma 185 - Tractor Dec 2010 Sep 2015 > 05 - Service & Maintenance > 05.100.04[01] - MAINTENANCE PARTS - FILTERS

Indicators	Ref	Qty	PN	Description	Usage
	1	1	84228488	ENGINE OIL FILTER 95mm OD x 171mm L, M27x2-6H	ENGINE OIL FILTER - 95mm OD x 171mm L, M27x2-6H; Engine Oil, Spin On, Every 600 hours; Valid with PUMA 170-TRACTOR, PUMA 185-TRACTOR, PUMA 200-TRACTOR, PUMA 215-TRACTOR Models
	2	1	87517154	AIR FILTER 281.6mm ID x 284.4mm OD x 319mm L	AIR FILTER - 281.6mm ID x 284.4mm OD x 319mm L; Main, Every 300 hours; Valid with PUMA 170-TRACTOR, PUMA 185-TRACTOR, PUMA 200-TRACTOR, PUMA 215-TRACTOR Models
	3	1	87517153	AIR FILTER 142.3mm ID x 150.9mm OD x 258mm L	AIR FILTER - 142.3mm ID x 150.9mm OD x 258mm L; Safety element, Every 300 hours; Valid with PUMA 170-TRACTOR, PUMA 185-TRACTOR, PUMA 200-TRACTOR, PUMA 215-TRACTOR Models
	4	1	84328598	FUEL FILTER Cleanable, 40mm OD x 109mm L, M14 x 1.5, 350 Microns	FUEL FILTER - Cleanable, 40mm OD x 109mm L, M14 x 1.5, 350 Microns; Precleaner, Every 600 hours; Valid with PUMA 170-TRACTOR, PUMA 185-TRACTOR, PUMA 200-TRACTOR, PUMA 215-TRACTOR Models
	5	1	84412164	FUEL FILTER 94mm OD x 192mm L, M20 x 1.5, 10 Microns, 12 Pack Qty	FUEL FILTER - 94mm OD x 192mm L, M20 x 1.5, 10 Microns, 12 Pack Qty; Primary, Every 300 hours; Valid with PUMA 170-TRACTOR, PUMA 185-TRACTOR, PUMA 200-TRACTOR, PUMA 215-TRACTOR Models
	6	1	84363730	FILTER, DEF 100 Micron	FILTER, DEF - 100 Micron; ADBLUE/DEF Tank, Every 300 hours; Valid with PUMA 170-TRACTOR, PUMA 185-TRACTOR, PUMA 200-TRACTOR, PUMA 215-TRACTOR Models
	7	1	84247272	FILTER, DEF In-Line	FILTER, DEF - In-Line; ADBLUE/DEF Tank, Every 300 hours; Valid with PUMA 170-TRACTOR, PUMA 185-TRACTOR, PUMA 200-TRACTOR, PUMA 215-TRACTOR Models

PUMA 185

Indicators	Ref	Qty	PN	Description	Usage
 	7	1	84254852	FILTER, DEF	FILTER, DEF; DeNOx2, Every 300 hours; Valid with PUMA 170-TRACTOR, PUMA 185-TRACTOR, PUMA 200-TRACTOR, PUMA 215-TRACTOR Models
 	8	1	47617638	HYDRAULIC OIL FILTER HYD oil filter element plus gasket	HYDRAULIC OIL FILTER - HYD oil filter element plus gasket; Hydraulic filter, Element, Every 600 hours; Valid with PUMA 170-TRACTOR, PUMA 185-TRACTOR, PUMA 200-TRACTOR, PUMA 215-TRACTOR Models
 	9	1	47617638	HYDRAULIC OIL FILTER HYD oil filter element plus gasket	HYDRAULIC OIL FILTER - HYD oil filter element plus gasket; Transmission/Pump, Every 600 hours; Valid with PUMA 170-TRACTOR, PUMA 185-TRACTOR, PUMA 200-TRACTOR, PUMA 215-TRACTOR Models, Valid with VAR. 729004, 728481 / 743616
	9	1	84226258	HYDRAULIC OIL FILTER Spin-on, 97mm OD x 240mm L, 1 3/8IN - 12 UNF	HYDRAULIC OIL FILTER - Spin-on, 97mm OD x 240mm L, 1 3/8IN - 12 UNF; Transmission/Pump, Every 600 hours
	9	1	84226263	HYDRAULIC OIL FILTER Spin-on, 119.4mm OD x 295.4mm L, 1 3/8IN - 12 UNF	HYDRAULIC OIL FILTER - Spin-on, 119.4mm OD x 295.4mm L, 1 3/8IN - 12 UNF; Transmission/Pump, Every 600 hours; Larger Filter to be used after the first 50h on Models with CCLS Hydraulic System/ Pump, Valid with PUMA 170-TRACTOR, PUMA 185-TRACTOR, PUMA 200-TRACTOR, PUMA 215-TRACTOR Models, Valid with STD
 	10	2	87726675	CAB FILTER Fresh Air, 550mm x 100mm x 64mm, Paper	CAB FILTER - Fresh Air, 550mm x 100mm x 64mm, Paper; Heating, Conditioning, w/High Profile Roof, Every 1200 hours; Valid with PUMA 170-TRACTOR, PUMA 185-TRACTOR, PUMA 200-TRACTOR, PUMA 215-TRACTOR Models
  	11	1	87726699	CAB FILTER Fresh Air, 380mm x 130mm x 49mm, Paper	CAB FILTER - Fresh Air, 380mm x 130mm x 49mm, Paper; Inner Thick Cartridge, Recirculation, Every 1200 hours; Valid with PUMA 170-TRACTOR, PUMA 185-TRACTOR, PUMA 200-TRACTOR, PUMA 215-TRACTOR Models

PUMA 185

Indicators	Ref	Qty	PN	Description	Usage
	12	1	47679344	BREATHER	BREATHER; ABS system control, Every 300 hours; Valid with PUMA 170-TRACTOR, PUMA 185-TRACTOR, PUMA 200-TRACTOR, PUMA 215-TRACTOR Models
  	13	1	84278636	FUEL FILTER 96.2mm OD x 183mm L, M16x1.5 - 6H, W/ WIF Sensor (M14)	FUEL FILTER - 96.2mm OD x 183mm L, M16x1.5 - 6H, W/ WIF Sensor (M14); Every 600 hours; Valid with PUMA 170-TRACTOR, PUMA 185-TRACTOR, PUMA 200-TRACTOR, PUMA 215-TRACTOR Models
	13	1	87722692	FUEL FILTER	FUEL FILTER; for Biodiesel, W/ WIF Sensor, Every 600 hours; Valid with PUMA 170-TRACTOR, PUMA 185-TRACTOR, PUMA 200-TRACTOR, PUMA 215-TRACTOR Models

Serial Number:

Magnum > Magnum 310 - Tractor - Tier 4b Cvt (row) Apr 2014 Jun 2020 > 05 - Service & Maintenance > 05.100.03[03] - FILTERS, CVT TIER 4B

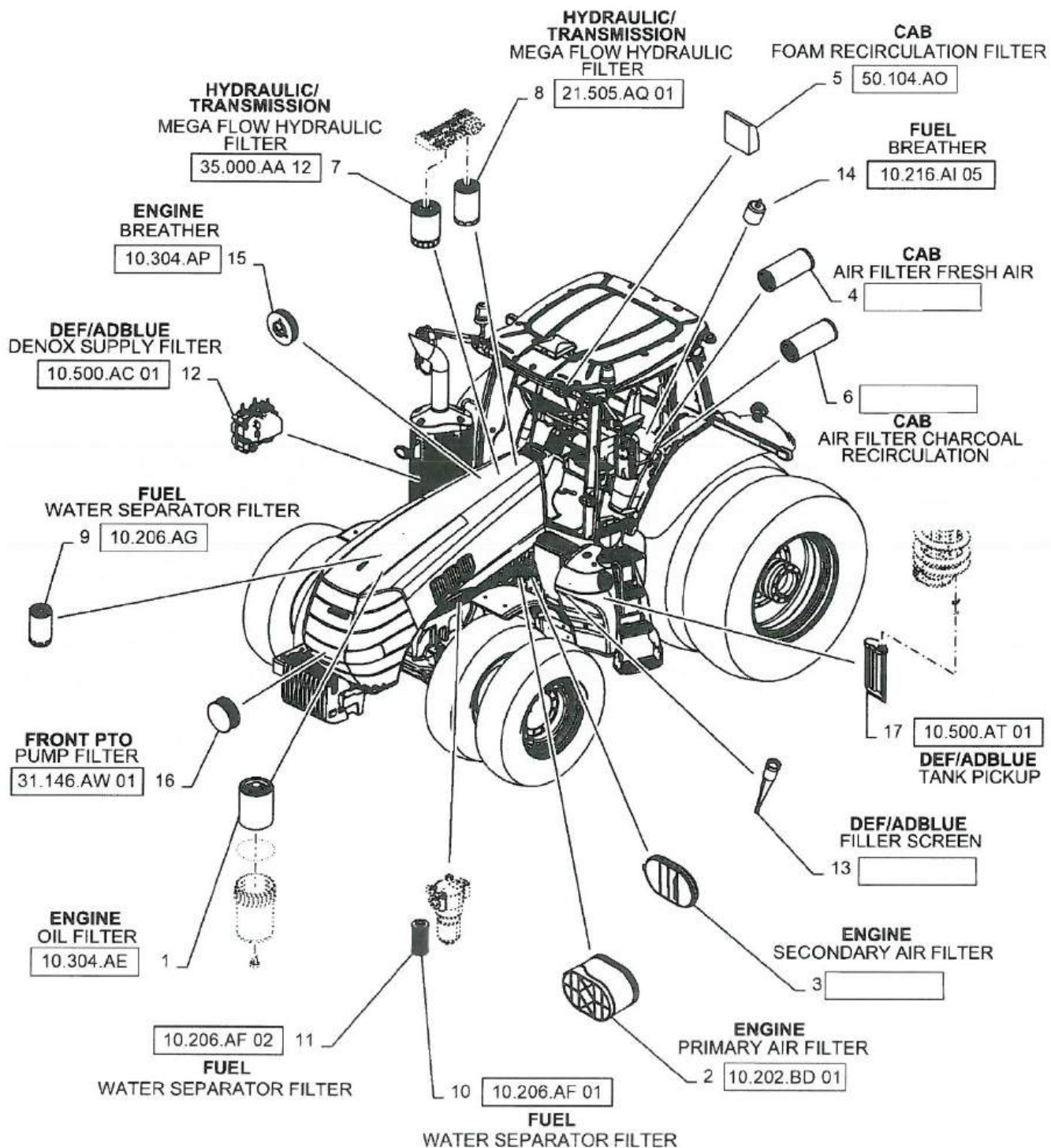

Verified by Engineering ✓

Serial Number:

Magnum > **Magnum 310** - Tractor - Tier 4b Cvt (row) Apr 2014 Jun 2020 > 05 - Service & Maintenance > 05.100.03[03] - FILTERS, CVT TIER 4B

Indicators	Ref	Qty	PN	Description	Usage
	1	1	504179764	ENGINE OIL FILTER	ENGINE OIL FILTER; Replace Every 600 Hours
	2	1	84191182	AIR FILTER 398mm L x 261mm W x 237mm Thk, Paper	AIR FILTER - 398mm L x 261mm W x 237mm Thk, Paper; Primary, Replace Every 1200 Hours
	3	1	87356547	AIR FILTER 240.5mm x 367.5mm	AIR FILTER - 240.5mm x 367.5mm; Secondary, Replace every 1200 Hours
	4	1	87684088	CAB FILTER CAB	CAB FILTER - CAB; Replace Every 400 Hours
	5	2	293615A1	CAB FILTER	CAB FILTER; Replace Every 400 Hours
	6	1	87267363	AIR FILTER Cab Charcoal Recirculation	AIR FILTER - Cab Charcoal Recirculation; Replace Every 400 Hours
	7	1	84240234	HYDRAULIC OIL FILTER Spin-on, 120.1mm OD x 367.9 L, M108 x 2.5	HYDRAULIC OIL FILTER - Spin-on, 120.1mm OD x 367.9 L, M108 x 2.5; (367.9 mm), CVT, Charge/Lube, Replace Every 1500 Hours
	8	1	47833564	HYDRAULIC OIL FILTER Spin-on, 98.8mm OD x 239.8mm L, M87 x 2.5	HYDRAULIC OIL FILTER - Spin-on, 98.8mm OD x 239.8mm L, M87 x 2.5; (239 mm) Replace Every 1500 Hours
	9	1	92039410	FUEL FILTER	FUEL FILTER; Fuel Filter, Engine Mounted, Replace Every 600 Hours
	10	1	84348882	FUEL FILTER Spin-on, 96.5mm OD x 184mm L, M16 x 1.5, 30 Microns	FUEL FILTER - Spin-on, 96.5mm OD x 184mm L, M16 x 1.5, 30 Microns; Standard, Replace Every 600 Hours
	11	1	84283691	FUEL FILTER Element, Cartridge	FUEL FILTER - Element, Cartridge; Severe Duty Cartridge Type, If Equipped, Replace Every 600 Hours
	12	1	47364243	FILTER, DEF	FILTER, DEF; Kit, DENOX2.2 Supply Module Replace Every 3600 Hours
	12	1	84247272	FILTER, DEF In-Line	FILTER, DEF - In-Line; DCU Module Inlet
	12	1	84367903	FILTER, DEF	FILTER, DEF; DEF/Adblue Supply Line, Replace Every 3600 Hours
	13	1	47680524	FILTER, DEF 100 Micron	FILTER, DEF - 100 Micron; DEF Fill, 100 Micron Replace as Required
	14	1	87433010	BREATHER 6.35mm OD	BREATHER - 6.35mm OD; Fuel Tank, Replace as Required

MAGNUM 310

Indicators	Ref	Qty	PN	Description	Usage
 	15	1	580165956 0	OIL SEPARATOR Centrifugal Blow-by Filter	OIL SEPARATOR - Centrifugal Blow-by Filter; Engine Breather, Replace Every 1500 Hours
	16	1	47433185	FILTER STRAINER	FILTER STRAINER; FPTO Pump Filter
 	17	1	51447338	FILTER, DEF	FILTER, DEF; DEF Tank Pickup, Incl Mesh Filter, O-Ring, and Spring Clip; (SN Break) From HRF02695

Serial Number:

Magnum > **Magnum 380** - Tractor - Tier 4b Cvt (row) Apr 2014 Apr 2020 > 05 - Service & Maintenance > 05.100.03[03] - FILTERS, CVT TIER 4B

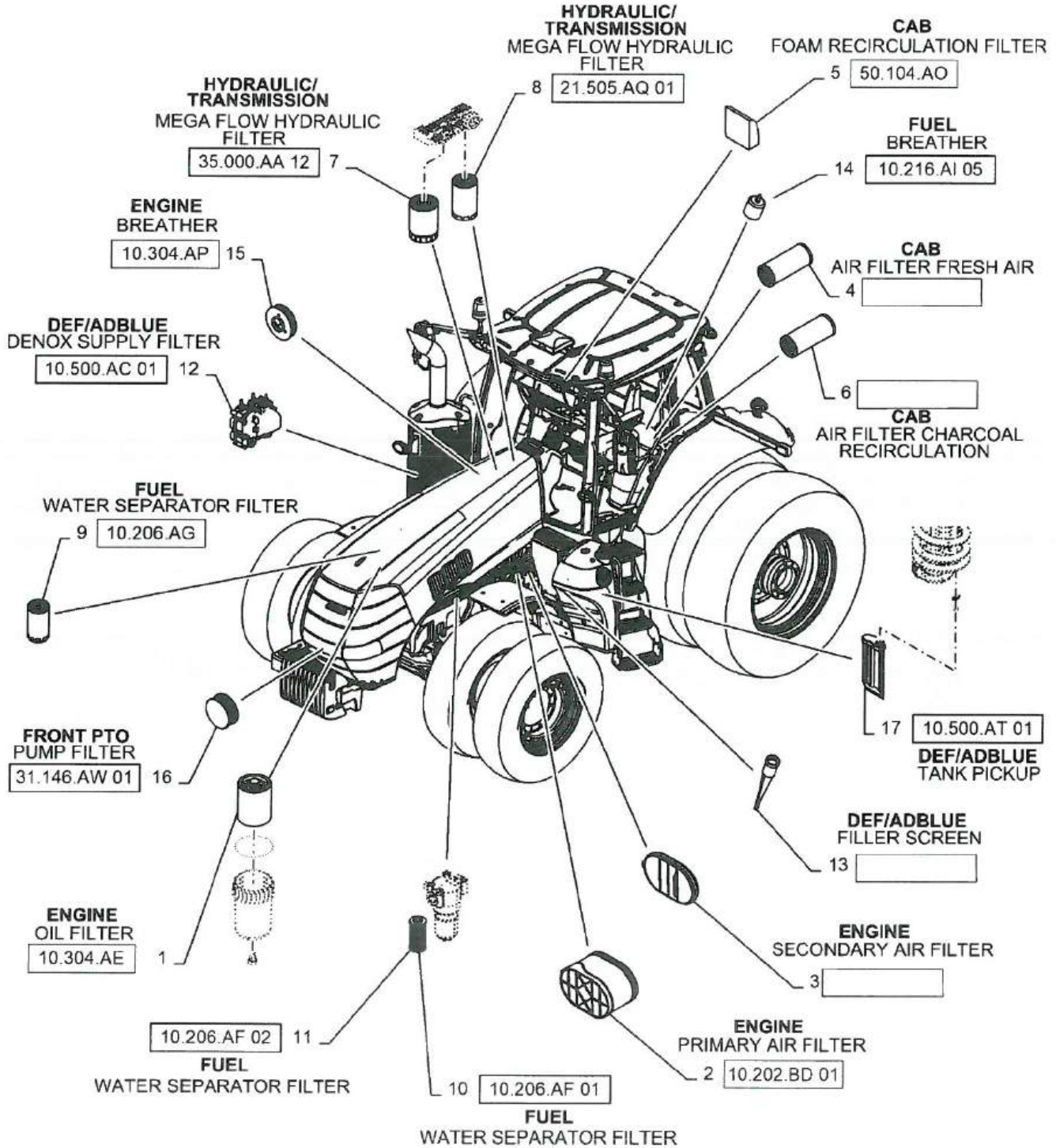

Verified by Engineering ✓

Serial Number:

Magnum > **Magnum 380** - Tractor - Tier 4b Cvt (row) Apr 2014 Apr 2020 > 05 - Service & Maintenance > 05.100.03[03] - FILTERS, CVT TIER 4B

Indicators	Ref	Qty	PN	Description	Usage
	1	1	504179764	ENGINE OIL FILTER	ENGINE OIL FILTER; Replace Every 600 Hours
	2	1	84191182	AIR FILTER 398mm L x 261mm W x 237mm Thk, Paper	AIR FILTER - 398mm L x 261mm W x 237mm Thk, Paper; Primary, Replace Every 1200 Hours
	3	1	87356547	AIR FILTER 240.5mm x 367.5mm	AIR FILTER - 240.5mm x 367.5mm; Secondary, Replace every 1200 Hours
	4	1	87684088	CAB FILTER CAB	CAB FILTER - CAB; Replace Every 400 Hours
	5	2	293615A1	CAB FILTER	CAB FILTER; Replace Every 400 Hours
	6	1	87267363	AIR FILTER Cab Charcoal Recirculation	AIR FILTER - Cab Charcoal Recirculation; Replace Every 400 Hours
	7	1	84240234	HYDRAULIC OIL FILTER Spin-on, 120.1mm OD x 367.9 L, M108 x 2.5	HYDRAULIC OIL FILTER - Spin-on, 120.1mm OD x 367.9 L, M108 x 2.5; (367.9 mm), CVT, Charge/Lube, Replace Every 1500 Hours
	8	1	47833564	HYDRAULIC OIL FILTER Spin-on, 98.8mm OD x 239.8mm L, M87 x 2.5	HYDRAULIC OIL FILTER - Spin-on, 98.8mm OD x 239.8mm L, M87 x 2.5; (239 mm) Replace Every 1500 Hours
	9	1	92039410	FUEL FILTER	FUEL FILTER; Fuel Filter, Engine Mounted, Replace Every 600 Hours
	10	1	84348882	FUEL FILTER Spin-on, 96.5mm OD x 184mm L, M16 x 1.5, 30 Microns	FUEL FILTER - Spin-on, 96.5mm OD x 184mm L, M16 x 1.5, 30 Microns; Standard, Replace Every 600 Hours
	11	1	84283691	FUEL FILTER Element, Cartridge	FUEL FILTER - Element, Cartridge; Severe Duty Cartridge Type, If Equipped, Replace Every 600 Hours
	12	1	47364243	FILTER, DEF	FILTER, DEF; Kit, DENOX2.2 Supply Module Replace Every 3600 Hours
	12	1	84247272	FILTER, DEF In-Line	FILTER, DEF - In-Line; DCU Module Inlet
	12	1	84367903	FILTER, DEF	FILTER, DEF; DEF/Adblue Supply Line, Replace Every 3600 Hours
	13	1	47680524	FILTER, DEF 100 Micron	FILTER, DEF - 100 Micron; DEF Fill, 100 Micron Replace as Required
	14	1	87433010	BREATHER 6.35mm OD	BREATHER - 6.35mm OD; Fuel Tank, Replace as Required

MAGNUM 380

Indicators	Ref	Qty	PN	Description	Usage
	15	1	580165956 0	OIL SEPARATOR Centrifugal Blow-by Filter	OIL SEPARATOR - Centrifugal Blow-by Filter; Engine Breather, Replace Every 1500 Hours
	16	1	47433185	FILTER STRAINER	FILTER STRAINER; FPTO Pump Filter
	17	1	51447338	FILTER, DEF	FILTER, DEF; DEF Tank Pickup, Incl Mesh Filter, O-Ring, and Spring Clip; (SN Break) From HRF02695